

99300 Series Electric Rolling Motor

For 1" - 3" (25.4mm - 76.2mm) Tube OD



Tube & Pipe Cleaners ◦ Tube Testers ◦ Tube Plugs ◦ Tube Removal ◦ Tube Installation



Operating and Maintenance Instructions

TABLE OF CONTENTS

Introduction	4
Safety Guidelines	5
Setup	7
Care & Maintenance	9
Brush Replacement.....	10
99300 Series Parts Diagram.....	11
99300 Series Parts List	12
Technical Information	13
Troubleshooting.....	16
Warranty	17

Introduction

Thank you for purchasing this Elliott product. More than 100 years of experience have been employed in the design and manufacture of this tool, representing the highest standard of quality, value and durability. Elliott tools have proven themselves in thousands of hours of trouble free field operation.

If this is your first Elliott purchase, welcome to our company; our products are our ambassadors. If this is a repeat purchase, you can rest assured that the same value you have received in the past will continue with all of your purchases, now and in the future.

The Elliott 99300 Series Electric Rolling Motor may be used with or without the Elliott Model ELC110220 Electronic Torque Controller to expand tubes in the following types of equipment:

Boilers

Heat Exchangers

Condensers

Chillers

Evaporators

Air Conditioners

If you have any questions regarding this product, manual or operating instructions, please call Elliott at +1 800 332 0447 toll free (USA only) or +1 937 253 6133, or fax us at +1 937 253 9189 for immediate service.

Safety Instructions



1. Read all safety and operating instructions contained in this manual prior to use of the tool. Failure to follow all instructions listed below may result in electrical shock, fire and/or serious injury.
2. Do not operate this tool while under the influence of drugs or alcohol.
3. Do not operate this tool in an explosive atmosphere, such as in the presence of flammable liquids, gases or dust.
4. Check the motor, cable and plug prior to every use of the tool. Repair or replace any defective parts prior to use of the tool.
5. Do not use motor in wet conditions.
6. Use only extension cords and plugs approved for outdoor use when working outdoors.
7. Use appropriate safety equipment (i.e. safety glasses, ear plugs, dust masks, etc.) when using this tool.
8. Ensure that long hair or loose fitting clothes are secure prior to use of the tool.
9. Do not use motor without the additional handle.
10. Never apply the motor to an unsecured work piece.
11. Power cable should be located to the rear of the motor during operation, away from the rotating spindle.
12. Always hold the motor with both hands and maintain a safe stance during use.
13. Stay clear of any objects that may interfere with the operator's ability to maintain control of the motor as it reaches maximum torque.
14. Always disconnect the motor from the power source prior to performing any maintenance or repairs.

Protection

To avoid damage to the tool and/or possible injury to the operator:

Do not continue to run the motor after the motor has reached its maximum torque.

Do not operate the motor beyond the maximum amperage rating shown on the name plate.

Use only original replacement parts from the motor manufacturer.

Safety Recommendations

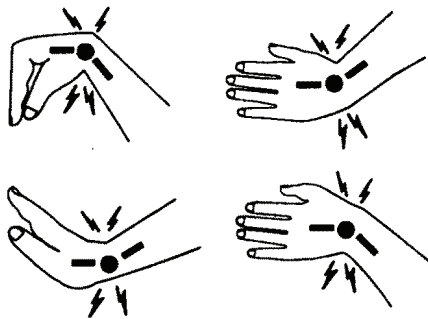

- Tasks should be performed in such a manner that the wrists are maintained in a neutral position which is not flexed, hyperextended, or turned side to side.
- Stressful postures should be avoided and can be controlled through tool selection and work location.

Any user suffering from prolonged symptoms of tingling, numbness, blanching of fingers, clumsiness or weakened grip, nocturnal pain in the hand, or any other disorder of the shoulders, arms, wrists, or fingers is advised to consult with a physician. If it is determined that the symptoms are job related or aggravated by movements and postures dictated by the job design it may be necessary for the employer to take steps to prevent further occurrences. These steps might include, but are not limited to, repositioning the workpiece or redesigning the workstation, reassigning workers to other jobs, rotating jobs, altering work pace, and/or changing the type of tool used so as to minimize stress on the operator. Some tasks may require more than one type of tool to obtain the optimum operator/tool/task relationship.

The following recommendations will help reduce or moderate the effects of repetitive work motions and/or extended vibration exposure.

- Use a minimum hand grip force consistent with proper control and safe operation.
- Keep wrists as straight as possible.
- Keep body and hands warm and dry.
- Avoid anything that inhibits blood circulation
 - Smoking tobacco
 - Cold temperatures
 - Certain drugs
- Avoid highly repetitive movements of hands and wrists, and continuous vibration exposure.

Setup

Side Handle

ONLY OPERATE THE MOTOR WITH THE SIDE HANDLE INSTALLED!

Hand-tighten the threaded end of the handle into the tapped hole located on the motor, opposite the trigger handle.

Speed Selection

DO NOT ATTEMPT TO CHANGE THE SPEED WHILE THE MOTOR IS RUNNING!

This motor is equipped with a mechanical two-speed gearbox. To select high speed, press in on the selector switch and slide the switch in the direction of the double arrows (>>). To select low speed, press in on the selector switch and slide the switch in the direction of the single arrow (<). If the switch will not slide completely, rotate the spindle slightly by hand while still pressing in on the switch until the gearbox engages and the switch slides the full distance.

Operating this motor in the high speed selection will yield faster RPMs for higher productivity and less torque than the low speed selection.

If the motor is running in the high speed selection and the torque controller is set at it's highest limit setting and the tubes are being under-expanded, switch the motor to the low speed selection and rerun the torque controller setup.

Connect to Torque Controller

To get full use of the torque shut-off feature, this motor must be used with the Elliott Model ELC110220 Electronic Torque Controller. Connect the power cord on the motor to one end of the included adapter cord and then connect the 7-pin connector on the adapter cord to the torque controller receptacle. The controller will automatically detect whether the motor is 110V or 220V and whether the motor is auto-reversing or manual reversing. For safety reasons the 99300 Series electric rolling motor is not auto-reversing, so it must be manually reversed after reaching torque shut-off. (Note: The operating voltage must correspond with the voltage indicated on the motor's name plate. 99300-110 motors designed for 110V can be used with 120V as well. 99300-220 motors designed for 220V can be used with 240V as well.

Setup

⚠ CAUTION

Electric motors are designed to operate within a specific amperage range. Operating above the maximum specified amperage rating will result in damage to the motor.

When operating the motor in conjunction with Elliott's ELC110220 Torque Controller the following maximum settings must be followed:

Model	Single Phase Voltage	Maximum Amperage	Maximum ELC110220 Setting
99300-110	110	16.0	750
99300-220	220	8.0	400

⚠ CAUTION

If using an extension cord, avoid excessive lengths and/or undersized wire gauge cords. The ELC110220 is designed to operate at a minimum voltage of 100 VAC. The use of an undersized extension cord can create a voltage drop that may adversely affect the operation of the ELC110220. An extension cord that is hot to the touch is most likely undersized and should be replaced with the next larger size wire.

Grounded power cords have plugs with three prongs and require a three wire extension cord. Double insulated power cords have plugs with two prongs and can use either two or three wire extension cords. As the distance from the supply outlet increases, you must use a heavier gauge extension cord. Using extension cords with inadequately sized wire causes a serious drop in voltage, resulting in loss of power. Refer to the chart below to determine the required minimum wire size.

Recommended Minimum Wire Gauge for Extension Cords

Nameplate Amperes	Extension Cord Length					
	25' (7.6m)	50' (15.2m)	75' (22.8m)	100' (30.5m)	150' (45.7m)	200' (61.0m)
5.1 - 8.0	16	16	14	12	10	-
15.1 - 20.0	10	10	10	-	-	-

Care & Maintenance

Environments with high ambient temperatures require closer attention to care and use. In order to achieve optimal motor performance consider the following:

- **Clean Power**–The use of a reliable, consistent power supply will help minimize voltage fluctuations that can be harmful to the motor.
- **Ambient Temperature**–As the ambient temperature rises, so does the need for cooling. When used in high ambient temperature conditions, operators should run the motor under no load for 10 to 15 seconds periodically during the shift to enable ambient air to pass through the motor and cool the internal parts. Frequency and duration of cooling periods are dependent on the ambient temperature. If using in conjunction with Elliott ELC110220, this practice will not adversely affect the performance of the controller.
- **Cooling Motors**–In the event that conditions are so extreme that the cooling recommendation above is not sufficient, operators should consider implementing a multiple motor system where motors are run for a short period of time then allowed to rest while a secondary motor is put into service. Alternating motors in this manner will allow the motor to cool and avoid damage due to overheating.
- **Internal Operation Temperature**–The operating temperature of the internal components must not reach 284 degrees Fahrenheit (140 degrees Celsius).

To ensure years of reliable operation, follow these simple care and maintenance suggestions:

- Keep the motor clean and free of dirt and other contaminants.
- Do not allow contaminants inside the motor housing.
- When the brush lengths are .25” (6.35mm) or less, brushes need to be replaced. (See instructions below.) Brushes should be replaced by a maintenance technician. They must be run in by a 20 minute idle run of the tool. Also, the condition of the commutator must be checked. In case of irregular coloring of the individual blades and surface crashes, send the tool to an authorized service center.

Environmental Protection



Raw Material Recycling instead of Waste Disposal

The components that make up this tool, as well as its packaging, are made of recyclable materials and should be disposed of in accordance with local rules and regulations.

Brush Replacement

When To Replace The Carbon Brushes:

When the brush lengths are .25" (6.35mm) or less, brushes need to be replaced. Brushes are field-serviceable components and should be replaced by a maintenance technician.

- 1. Disconnect motor from any power source.**
2. Remove (4) back screws (Item 18) & remove motor cap (Item 17).
3. Lift up the flat spring to remove the carbon brush (Item 7) from the brush holder (Item 5).
4. Remove the screw & lock washer holding the wire terminal attached to the carbon brush & detach the carbon brush from the holder.
5. Attach the wire terminal of the new carbon brush with the screw & lock washer. (IMPORTANT: Ensure that the wire lead on the carbon brush terminal is under the contact washer).
6. Lift up the flat spring & insert the new carbon brush into the brush holder & release the flat spring to hold the carbon brush in place.
7. Repeat steps 2 thru 5 for replacing the carbon brush on the other side of the rotor complete (Item 1).
8. Replace motor cap (Item 17) and (4) back screws (Item 18).

99300 Series Parts Diagram

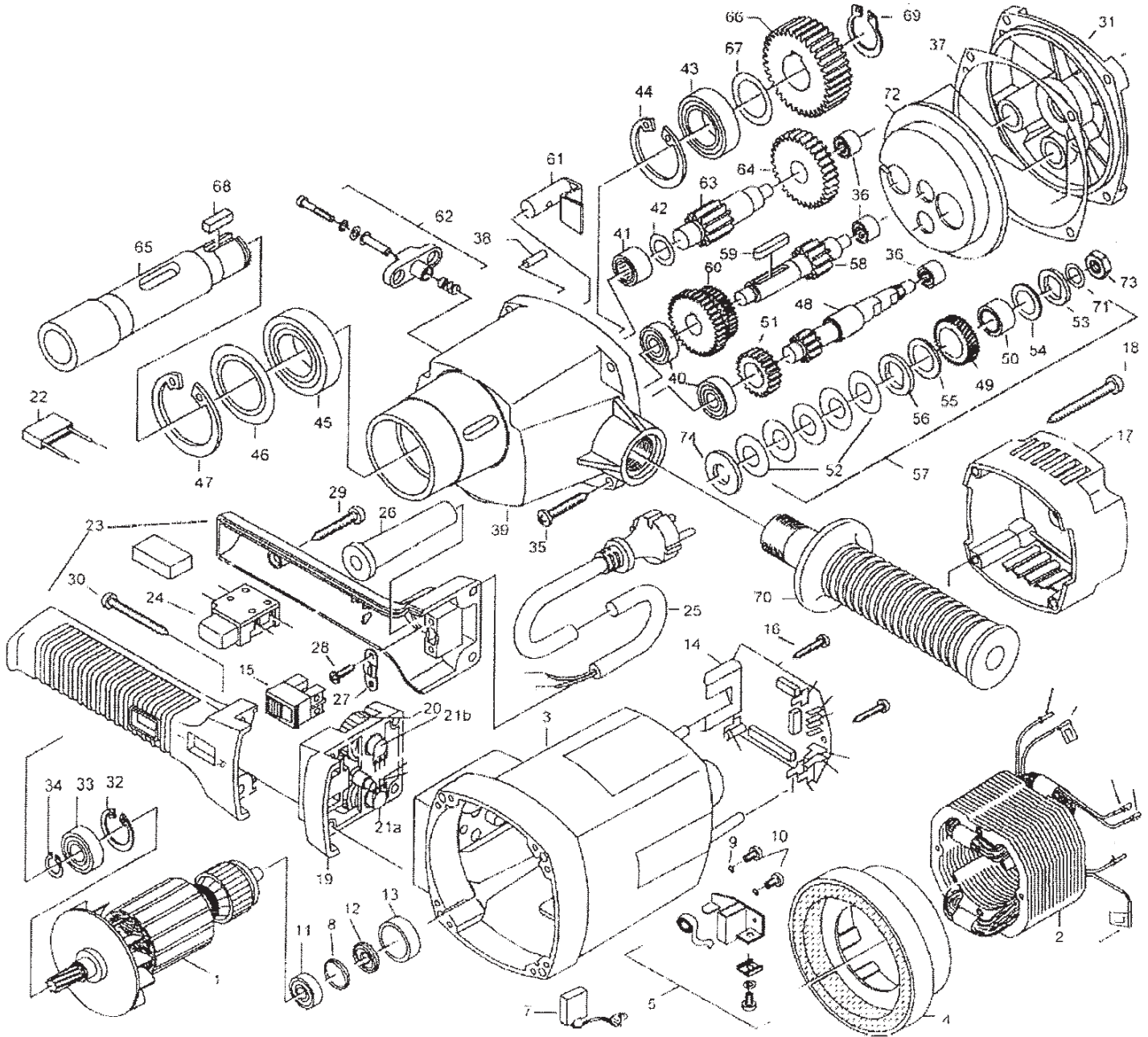

99300 Series Parts List

Item No.	Part Number	Description
1	40-74321100	Rotor Complete (110V)
	40-7154E100	Rotor Complete (220V)
2	40-71528150	Stator Complete (110V)
	40-74326150	Stator Complete (220V)
3	40-7742A200	Motor Housing
4	40-71540140	Air Guiding Ring
5	40-80201199	Carbon Brush Holder
7	40-80700021	Carbon Brushes
8	40-73320999	Disk
9	40-80201385	Spring Disk 34
10	40-80201181	Screw M4x12
11	40-80410021	Ball Bearing
12	40-80701002	Magnet Ring
13	40-73320315	Bearing Seal
14	40-74329280	Circuit Board (110V)
	40-74326280	Circuit Board (220V)
15	40-80600110	Reverser
16	40-80201260	Self Tapping Screw
17	40-7742A240	Motor Cap
18	40-80201267	Screw
19	40-7152B293	Spacer
20	40-71521230	Selector Wheel
21a	40-80500020	Speed Dial
21b	40-80500007	Torque Dial
22	40-80500010	Condenser
23	40-71527260	Side Handle
24	40-80600114	Switch
25	40-80600060	Connection Cable
26	40-71323255	Cable Sleeve
27	40-71540330	Locking Flange
28	40-80201271	Screw 4.2x16
29	40-80201291	Screw
30	40-80201294	Self Tapping Screw
31	40-7152B610	End Shield
32	40-80201333	Safety Ring 28/1.2
33	40-80410031	Bearing
34	40-80201320	Safety Ring
35	40-80201292	Screw 4.2x16
36	40-80420110	Needle Sleeve
37	40-74429620	Paper Seal
38	40-80200580	Notched Pin 5x16
39	40-71521400	Gearbox Housing

Item No.	Part Number	Description
40	40-80410020	Bearing
41	40-80420001	Needle Bearing
42	40-71540517	Needle Bearing Disk
43	40-80410061	Ball Bearing
44	40-80201336	Locking Ring
45	40-80410070	Grooved Ball Bearing
46	40-71540426	Disk Grooved Ball Bearing
47	40-80201338	Locking Ring
48	40-71526490	Intermediate Shaft 1
49	40-7154E550	Coupling Wheel
50	40-80420240	Gear Sleeve
51	40-71521470	Intermediate Wheel 1
52	40-80200716	Spring Washer
53	40-73116496	Washer
54	40-73116497	Washer
55	40-73430498	Clutch Washer
56	40-73430499	C-Clip
57	40-71526493	Coupling Complete
58	40-71526500	Intermediate Shaft 2
59	40-80200602	Key
60	40-71521440	Cluster Gears
61	40-71521520	Coupling Bolt
62	40-71540545	Gear Switch
63	40-71521510	Intermediate Shaft 3
64	40-71526480	Intermediate Wheel 2
65	40-71540420	Work Spindle
66	40-71540430	Spindle Wheel
67	40-80200512	Fitting Disk
68	40-80200606	Key
69	40-80201326	Locking Ring
70	40-71526590	Tube Handle Complete
71	40-80200710	Disk Spring
72	40-7152B625	Grease Chamber
73	40-80201007	Hex Nut 8M 10 x 1
74	40-71540517	Needle Bearing Disk

Technical Information

Rated Voltage:	110V / 120V (99300-110)	220V / 240V (99300-220)
Rated Power Input (Watts):	1800	
Frequency:	50 – 60 Hz	
Max. Amperage:	16A (110V)	8A (220V)
ELC110220 Limit Setting:	750 (110V)	400 (220V)
Load Speed:	30-75 (Low Gear) / 90-230 (High Gear)	
Max. Torque (Ft.-Lbs. / N*m):	33.9 / 46 @ 228 RPM (High Gear) 84.8 / 115 @ 73 RPM (Low Gear)	
Protection Class:	II (Double Insulation)	
Degree of Protection:	IP 20	
Interference Suppression:	as per DIN VDE 0875, EN 55014	

All rights of changes due to technical development reserved.

Dimensions (without toolbox):

Length (Inches / mm):	16 / 406.4
Width (Inches / mm):	5 / 127
Height (Inches / mm):	33.5 / 850.9 (w/ Side Handle)
Weight (Lbs. / Kg):	17 / 7.7

Dimensions (with toolbox):

Length (Inches / mm):	18 / 457.2
Width (Inches / mm):	5 / 127
Height (Inches / mm):	32 / 812.8
Weight (Lbs. / Kg):	21.2 / 9.6

Noise Emission:

Noise emission figures are based on DIN 45 649, part 2, DIN 45 635, part 21, and DIN EN 27 574 (ISO 7574).

- noise level (LWAc) (94+3) dB re 1 pW
working place-related emission figure (LpA) 84 dB per DIN 45635 – 21 – KL 2
- noise level (LWA) 88 dB re 1 pW
working place-related emission figure (LpA, cyc) 79 dB per DIN 45635.

Performance Measurement

Voltage	
110 V	1. Speed Rotation CW

Torque [Nm]	Power Input[W]	Speed [rpm]	Current[Amps]	Power Output[W]	cos φ
0	200	76	3,55	0,00	0,51
38	590	75	7,63	299,35	0,70
77	980	74	11,00	590,32	0,81
115	1370	73	13,70	872,92	0,91
153	1690	68	16,30	1088,53	0,94
192	2000	61	19,00	1224,60	0,96
230	2300	53	21,90	1281,12	0,95

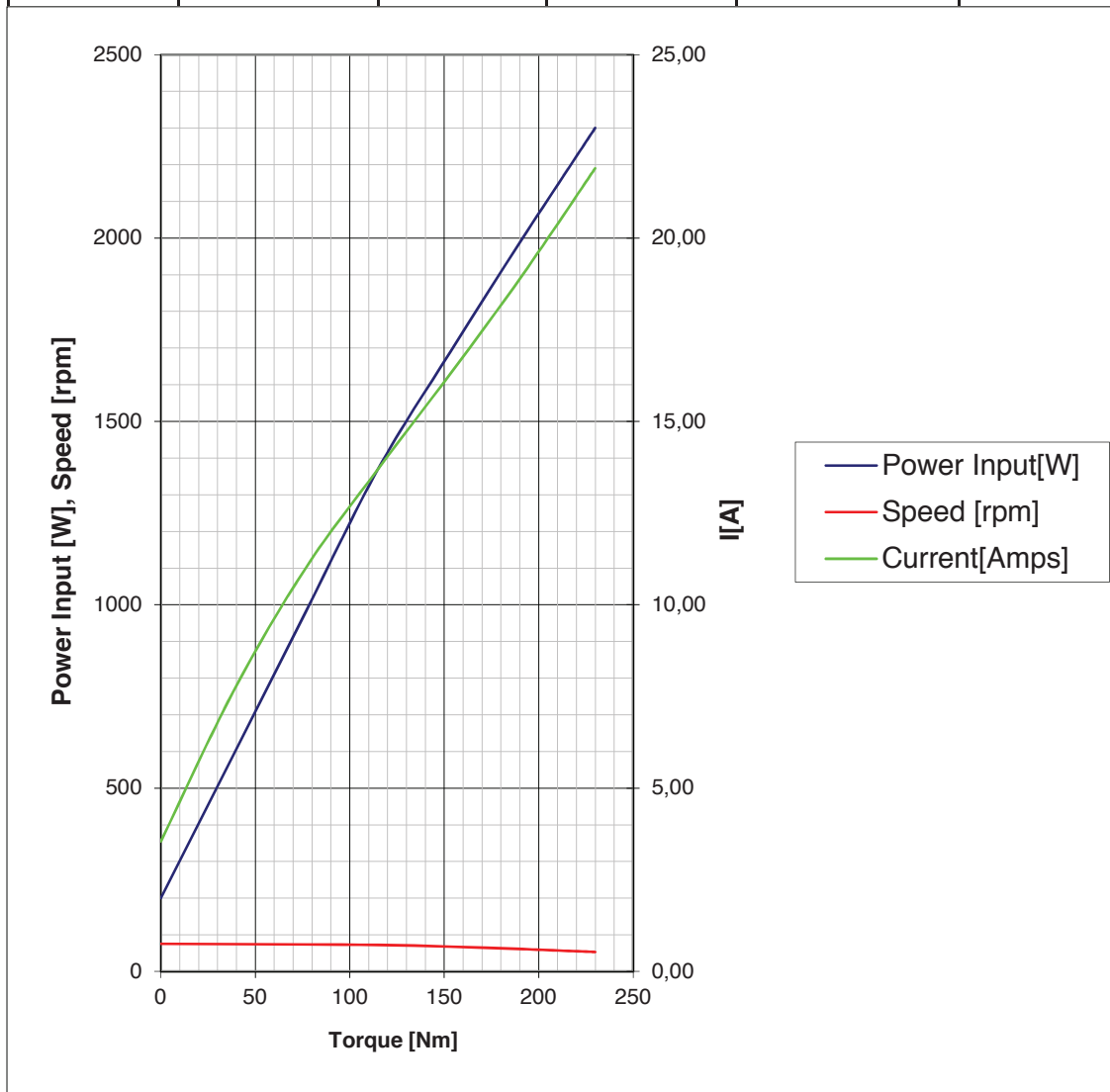

Performance Measurement

Voltage	
110 V	2. Speed Rotation CW

Torque [Nm]	Power Input[W]	Speed [rpm]	Current[Amps]	Power Output[W]	cos φ
0	200	253	3,55	0,00	0,51
11	590	251	7,63	288,98	0,70
23	980	247	11,00	594,61	0,81
34	1370	244	13,70	868,31	0,91
46	1690	228	16,30	1097,74	0,94
57	2000	205	19,00	1223,03	0,96
68	2300	179	21,90	1274,00	0,95

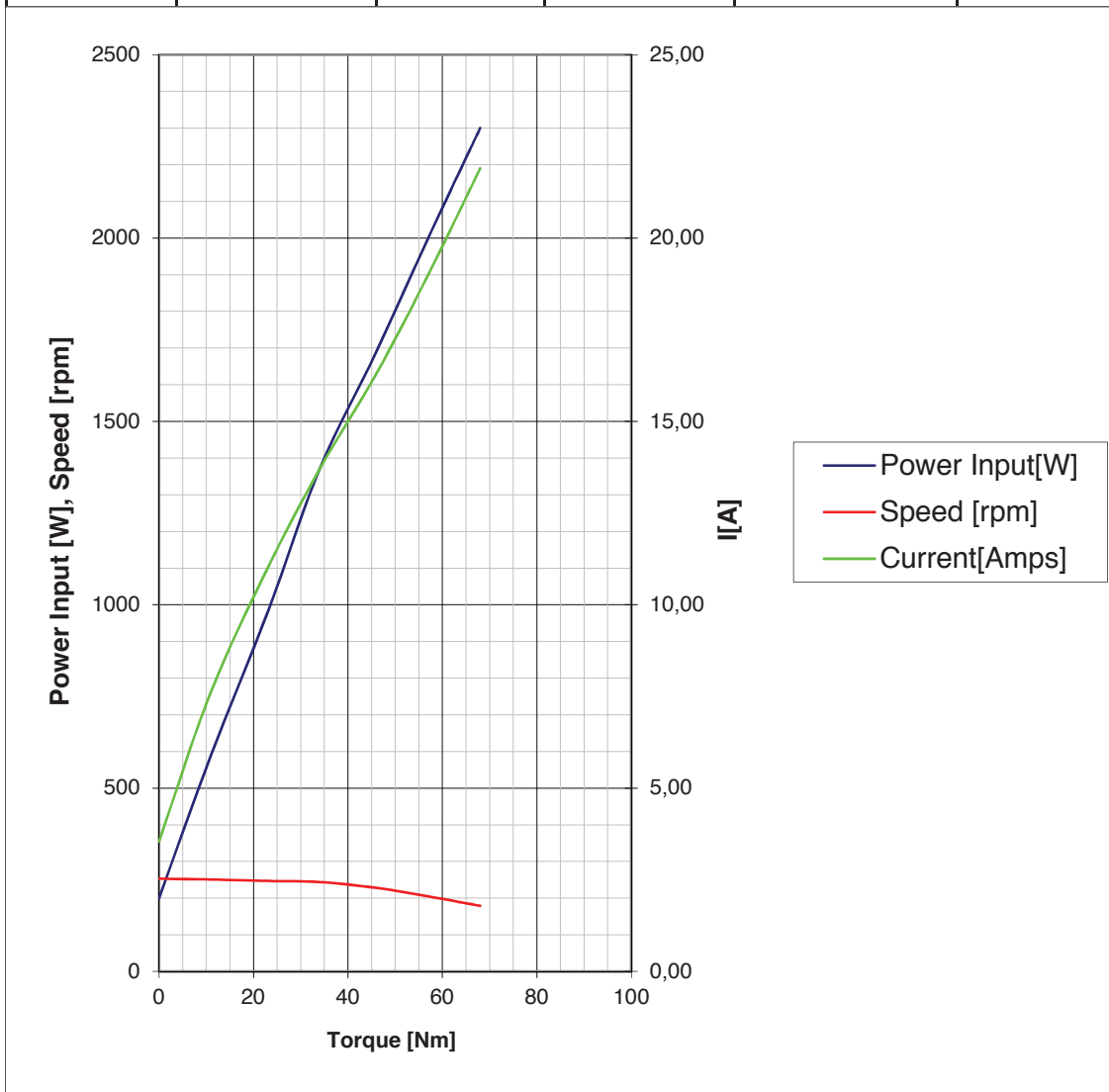

Troubleshooting Electric Rolling Motors

Symptom	Possible Causes	Solution
Motor won't run.	Loose plug connections.	Ensure all plug connections are secure.
	Motor voltage doesn't match power source voltage.	Ensure that motor voltage matches the voltage of the power source.
	Torque controller is in "Auto" or "Assisted" mode & is waiting for additional input.	Check the torque controller dialog screen & enter info required.
Motor will not shut off at controller setting.	Limit setting on the torque controller is set too high.	Recalculate or reduce limit setting.
	Torque required exceeds motor capacity.	Set motor speed (if 2-speed) to lower speed or switch to larger motor.
	Motor set at low speed setting (2-speed motors only).	Set motor to high speed setting.
	Motor is too large for application.	Switch to a smaller motor.
	Defective trigger switch.	Replace the trigger switch.
	Defective motor.	Have the motor serviced by an authorized repair specialist.
Motor runs hot.	Motor is operating at or above its max. amperage rating.	Set motor speed (if 2-speed) to lower speed or switch to larger motor.
	Ambient temperature are high.	See Care & Maintenance on page 10.
	Defective motor.	Have the motor serviced by an authorized repair specialist.
Motor will not auto-reverse.	Loose plug connection.	Ensure plug connection to torque controller is secure.
	Motor is not auto-reversible	Motor must be manually reversed.

WARRANTY

Should any part, of Seller's own manufacture, prove to have been defective in material or workmanship when shipped (as determined by Seller), Seller warrants that it will, at its sole option, repair or replace said part f.o.b., point of manufacture, provided that Buyer notifies, in writing, of such defect within twelve (12) months from date of shipment from the manufacturing plant.

On request of Seller, the part claimed to be defective will be returned, transportation, insurance, taxes and duties prepaid, to the factory where made, for inspection. Any item, which has been purchased by Seller, is warranted only to the extent of the original manufacturer's warranty to Seller. Seller shall not be liable for any damages or delays caused by defective material or workmanship.

No allowance will be made for repairs or alterations made by others without Seller's written consent or approval. If repairs or alterations are attempted without Seller's consent, Seller's warranty is void.

THE WARRANTIES PROVIDED IN THE OBLIGATIONS AND LIABILITIES OF SELLER HEREUNDER, AND THE RIGHTS AND REMEDIES OF BUYER HEREUNDER ARE EXCLUSIVE AND IN SUBSTITUTION FOR, AND BUYER HEREBY WAIVES ALL OTHER WARRANTIES, GUARANTEES, OBLIGATIONS, CLAIMS FOR LIABILITIES, RIGHTS AND REMEDIES, EXPRESS OR IMPLIED, ARISING BY LAW OR OTHERWISE, INCLUDING BUT NOT LIMITED TO THE IMPLIED WARRANTY FOR MERCHANTABILITY AND FITNESS FOR PURPOSE.

Seller's total liability is limited to the lower of the cost of repair or replacement.

This page intentionally left blank.

This page intentionally left blank.



Contact Us

Elliott Tool offers a complete line of precision tube tools to meet your needs. Contact us or your local support.

Elliott Tool Technologies, Ltd.
1760 Tuttle Avenue
Dayton, Ohio 45403-3428
Phone: +1 937 253 6133 • +1 800 332 0447
Fax: +1 937 253 9189
www.elliott-tool.com

Printed in the USA
©04/2019 Elliott Tool Technologies, Ltd.
TM-107
PL-79

Locally Supported By:

www.elliott-tool.com/support